

SUPERIOR **BOILER**

BUILT TO **OUTPERFORM**



SHAWNEE

Ds-TYPE WATERTUBE BOILER

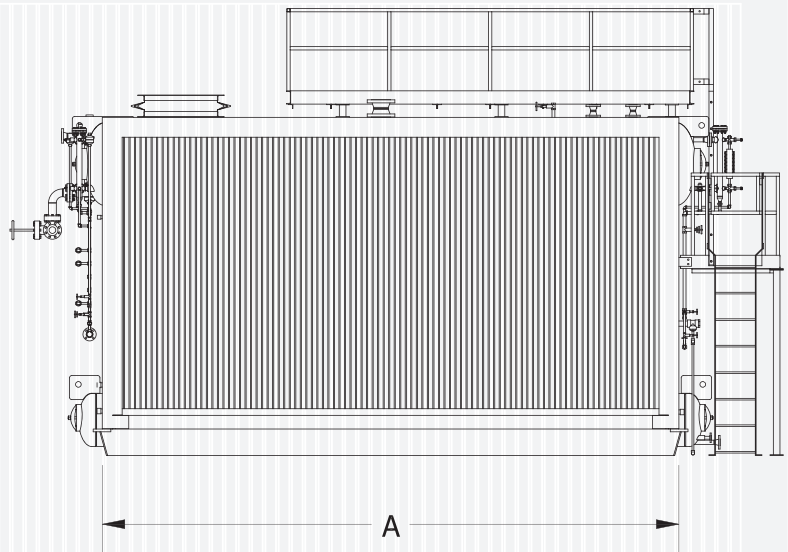
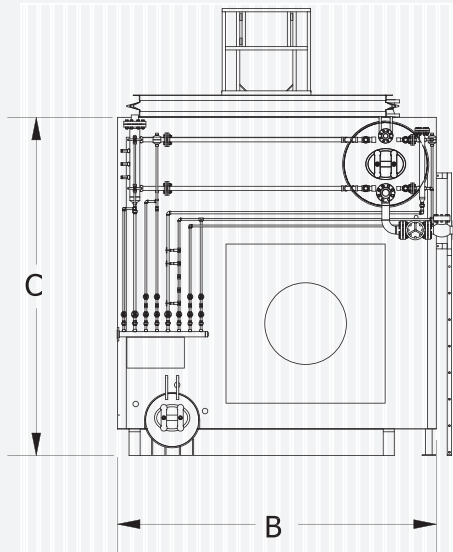

- + Patented design provides unmatched compact footprint
- + Square furnace with uniform heat flux promotes lower emissions
- + Lower operational cost given smaller FD fan motor HP
- + Gas outlet configuration: top, left, or right side
- + Capacities from 10,000 - 250,000 lb/hr
- + Design pressure up to 1,200 psig
- + Superheated steam temperature up to 900°F
- + Available as a Modular Boiler System

	LENGTH (A)	WIDTH (B)	HEIGHT (C)
30,000 LB/HR	183 in.	120 in.	156 in.
40,000 LB/HR	195 in.	132 in.	156 in.
50,000 LB/HR	213 in.	132 in.	156 in.
60,000 LB/HR	237 in.	132 in.	160 in.
70,000 LB/HR	255 in.	132 in.	170 in.
80,000 LB/HR	273 in.	136 in.	174 in.
90,000 LB/HR	285 in.	140 in.	177 in.
100,000 LB/HR	310 in.	148 in.	177 in.
125,000 LB/HR	351 in.	148 in.	187 in.
150,000 LB/HR	411 in.	148 in.	187 in.
175,000 LB/HR	449 in.	150 in.	191 in.
200,000 LB/HR	504 in.	150 in.	191 in.



Superior Boiler leads the way in the design and manufacture of industrial and commercial boilers for all market segments. With over 100 years' experience in the industry, our customers don't just trust what we build, they trust the people who build them. Complete boiler systems built to exacting standards, **made in the USA**, and installed throughout the world.