

APP. TYPE	QTY
LX-250-16	-
LX-300-16	-

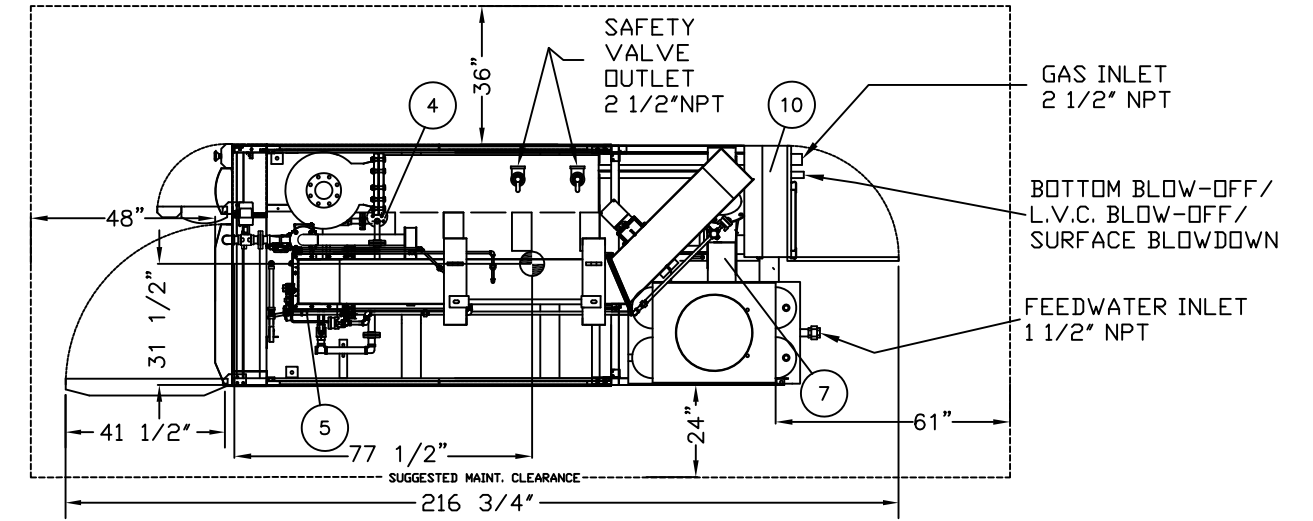

LEGEND		QTY
1	BOILER VESSEL	1
2	STEAM SEPARATOR	1
3	ECONOMIZER	1
4	LIQUID VOLUME CONTROL	1
5	BURNER	1
6	AIR DUCT	1
7	BLOWER	1
8	CONTROL BOX	1
9	BYPASS GAS VALVE	1
10	INVERTER BOX	1

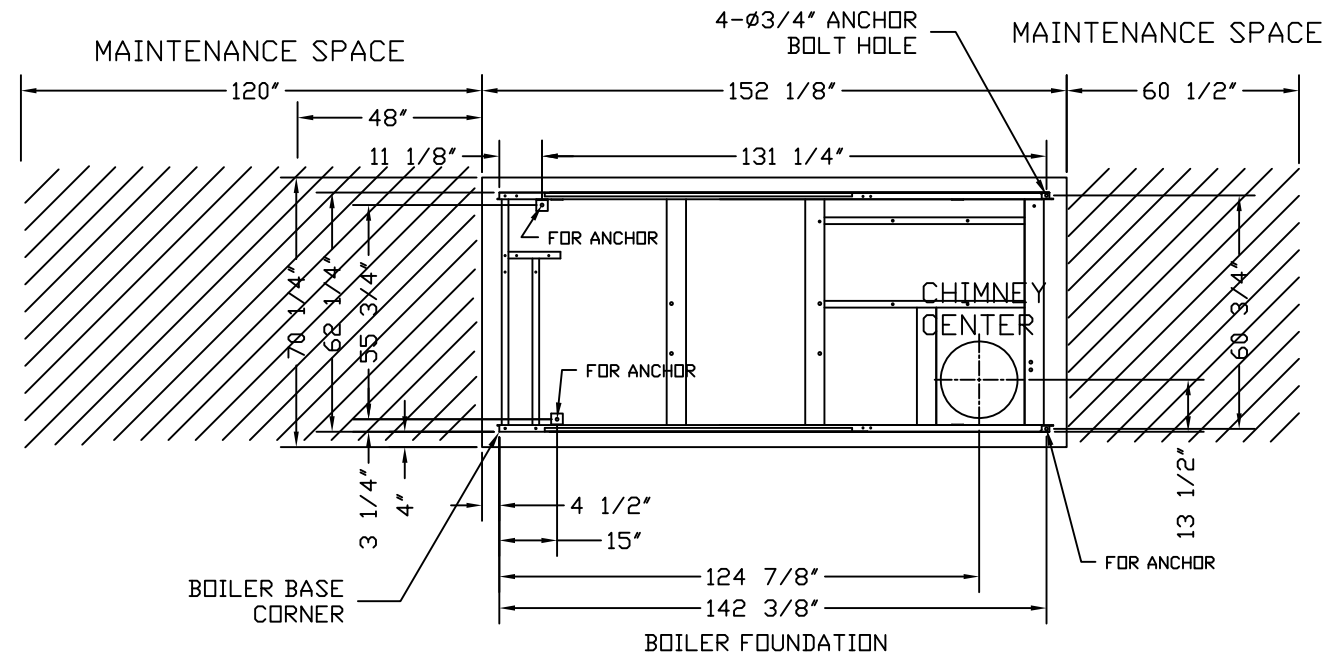
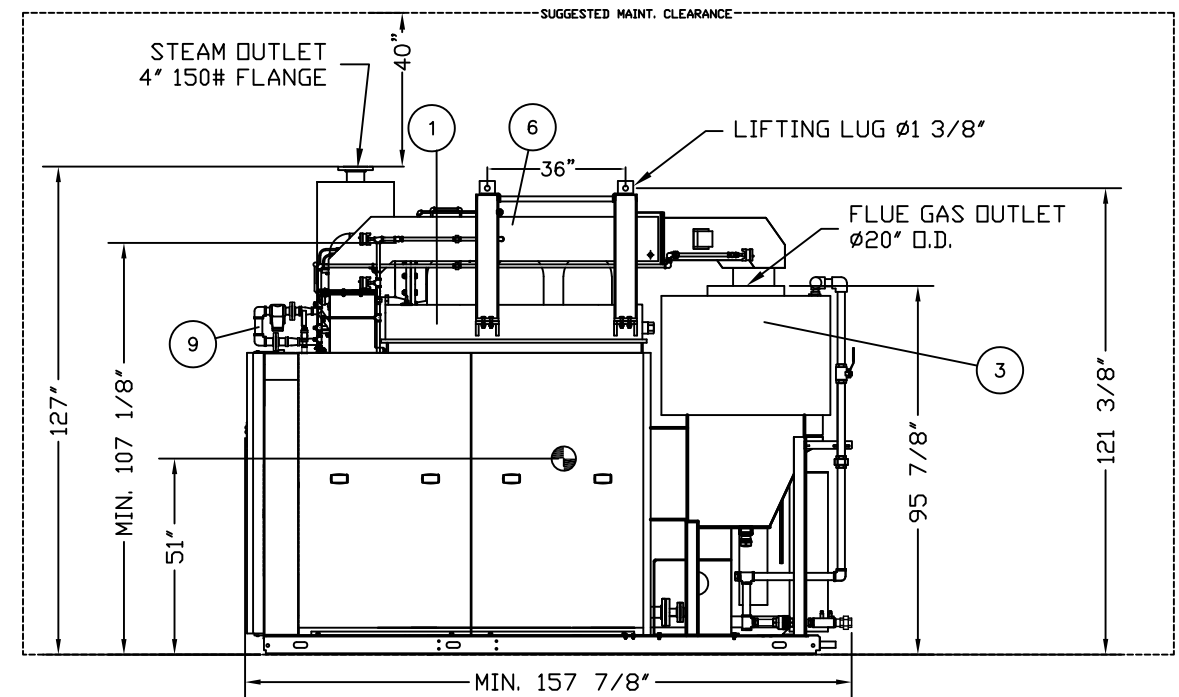
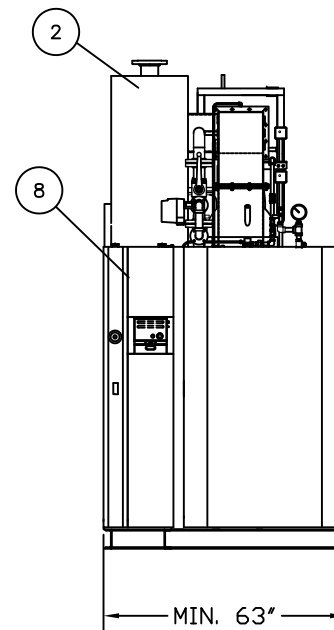

NOTE:

- 1) DIMENSIONS, SPECIFICATIONS, AND SOME PIPING ARE SUBJECT TO CHANGE WITHOUT NOTICE
- 2) UL CLEARANCE TO COMBUSTIBLE WALLS AND CEILINGS:

ABOVE	18"
FRONT	48"
SIDES	18"
REAR	18"
VENT CONNECTOR	18"
IN FRONT OF INVERTER DOOR (IF APPLICABLE)	48"
- 3) LOCAL CODES AND REGULATIONS MAY REQUIRE LARGER CLEARANCES THAN INDICATED HERE.

⊕ CENTER OF GRAVITY LOCATION.

MIURA

FOR REFERENCE ONLY.
DESIGN SUBJECT TO CHANGE
WITHOUT NOTICE. ALL INTELLECTUAL
PROPERTY RIGHTS RESERVED BY
MIURA AMERICA CO., LTD.

DESCRIPTION:
BOILER ASS'Y OUTSIDE VIEW

THIRD ANGLE SYSTEM
DRAWING NUMBER
LX16-0300-0W11