

APP. TYPE	QTY
LX-50SG-12	1

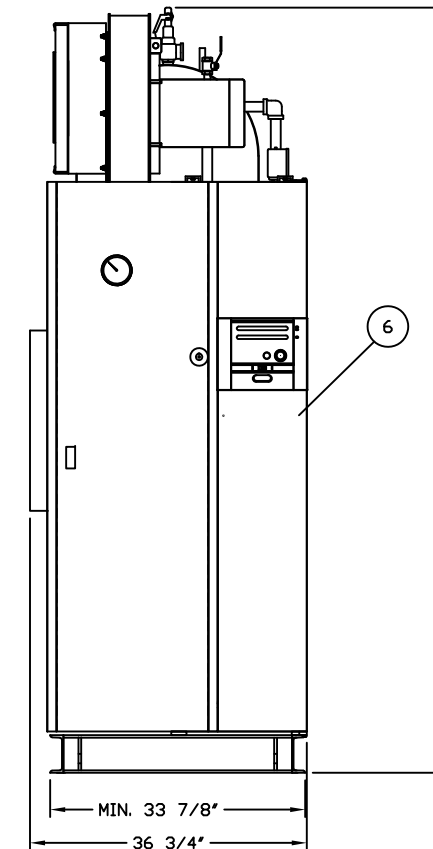
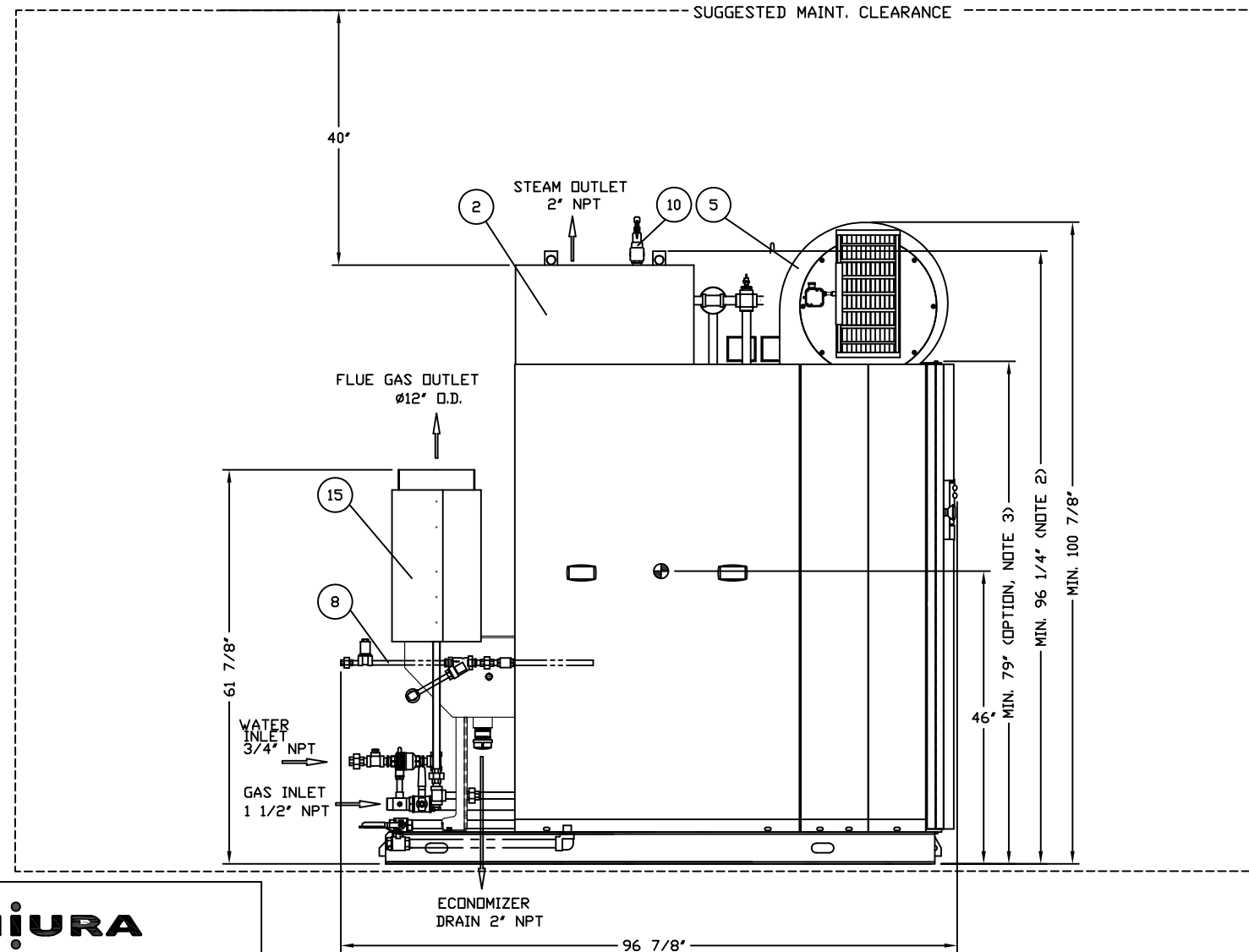
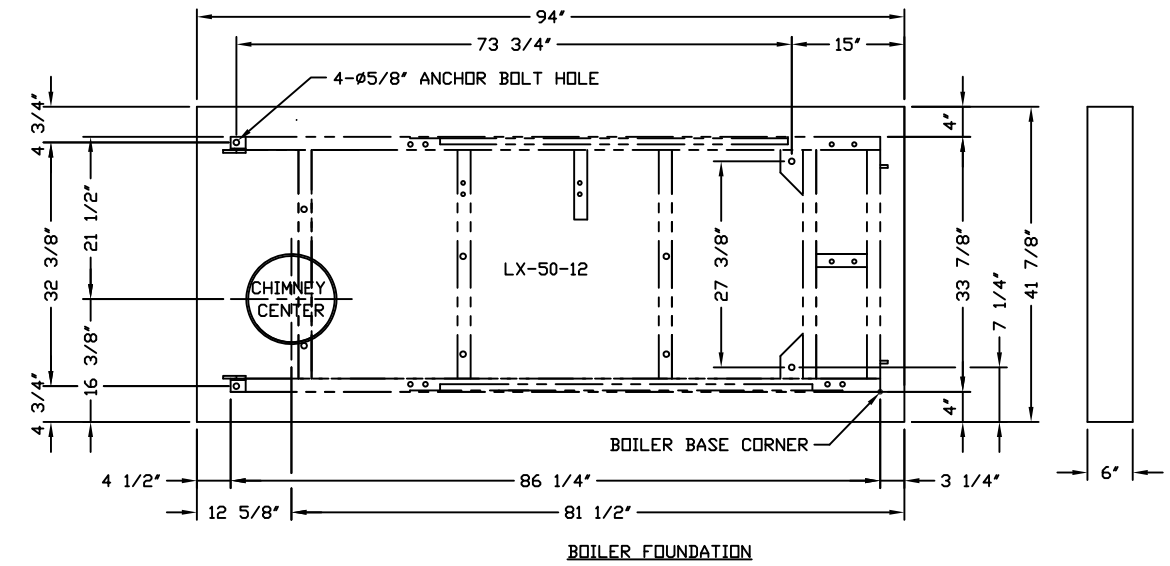
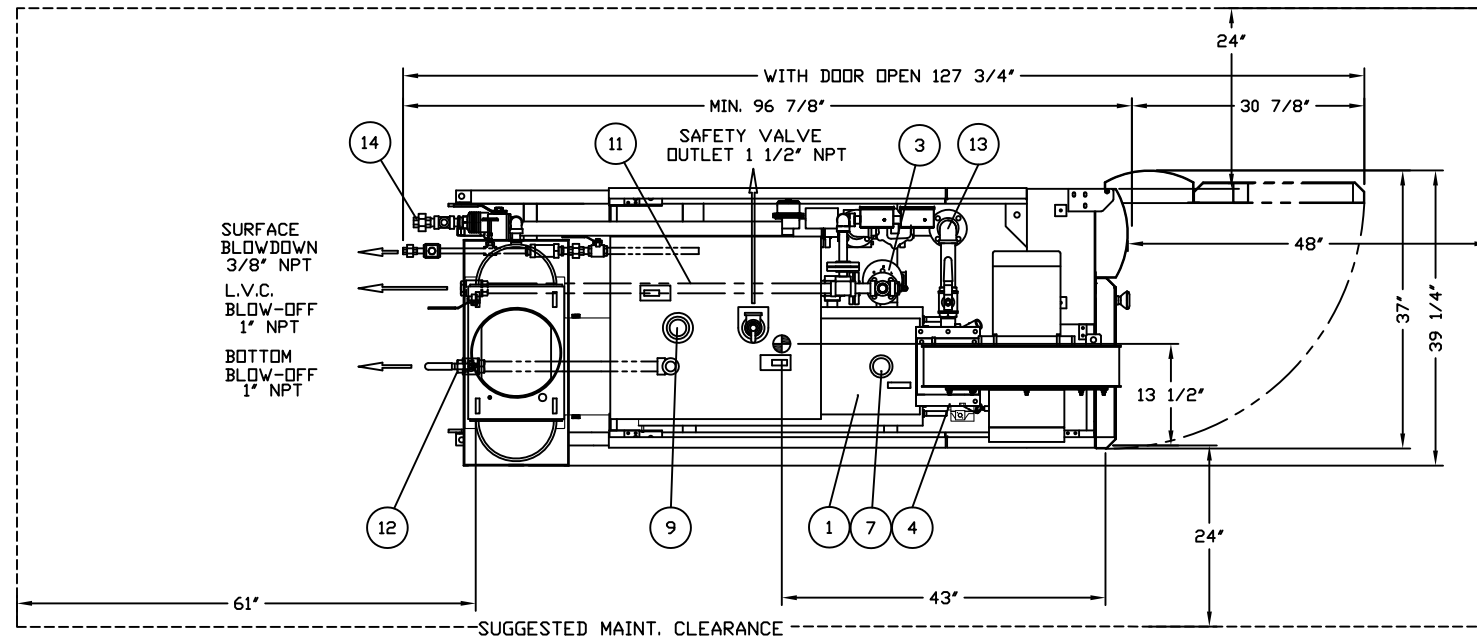

NOTE:

- DIMENSIONS, SPECIFICATIONS & SOME PIPINGS ARE SUBJECT TO CHANGE WITHOUT NOTICE.
- MINIMUM HEIGHT WITH SAFETY VALVE & BLOWER ASSY. DISMANTLED.
- OPTION : MINIMUM HEIGHT WITH SEPARATOR , BLOWER ASSY, & L.V.C ASSEMBLY DISMANTLED.
- UL CLEARANCE TO COMBUSTIBLE WALLS AND CEILINGS:

ABOVE	18"
FRONT	48"
SIDES	18"
REAR	18"
VENT CONNECTOR	18"
IN FRONT OF INVERTER DOOR (IF APPLICABLE)	48"

- LOCAL CODES AND REGULATIONS MAY REQUIRE LARGER CLEARANCES THAN INDICATED HERE.

⊙ CENTER OF GRAVITY LOCATION.

LEGEND

1	BOILER VESSEL	1
2	STEAM SEPARATOR	1
3	LIQUID VOLUME CONTROL	1
4	WIND BOX	1
5	BLOWER	1
6	CONTROL BOX	1
7	INSPECTION HOLE	2
8	SURFACE BLOWDOWN	1
9	STEAM OUTLET	1
10	MAIN SAFETY VALVE	1
11	LVC BLOW-OFF	1
12	BOTTOM BLOW-OFF	1
13	MAIN GAS TRAIN	1
14	FEEDWATER PIPING	1
15	ECONOMIZER	1

MIURA

FOR REFERENCE ONLY.
DESIGN SUBJECT TO CHANGE
WITHOUT NOTICE. ALL INTELLECTUAL
PROPERTY RIGHTS RESERVED BY
MIURA AMERICA CO., LTD.

DESCRIPTION:
BOILER ASS'Y OUTSIDE VIEW

THIRD ANGLE SYSTEM
DRAWING NUMBER
LX12-0050-OW66