

ZF350W-XP

CHIMNEY FLANGE DIMS:
 O.D. = 17"
 I.D. = 12-1/4"
 B.C.D = 14-1/2"
 NO. OF HOLES = 8
 HOLE DIAMETER = 0.53"

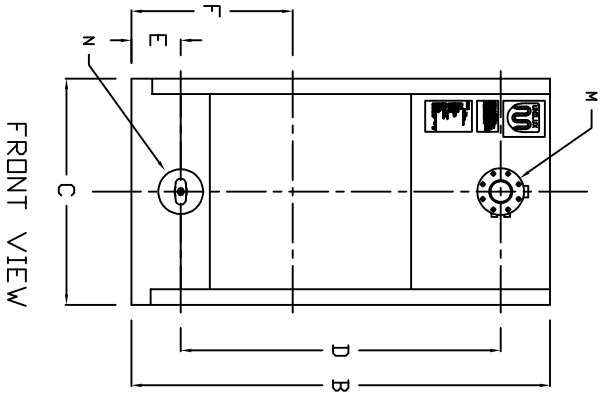

FRONT VIEW

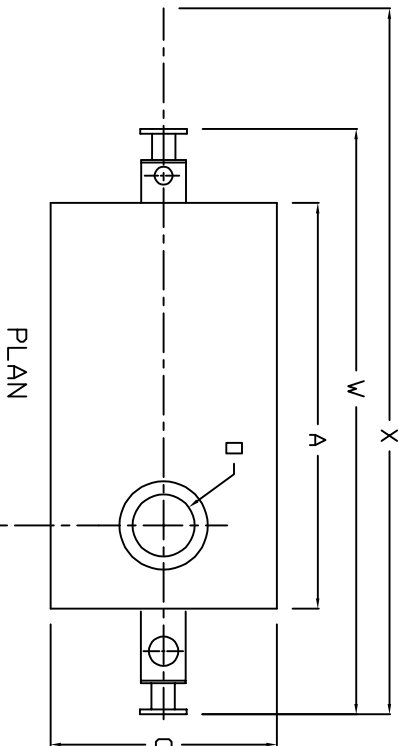

PLAN

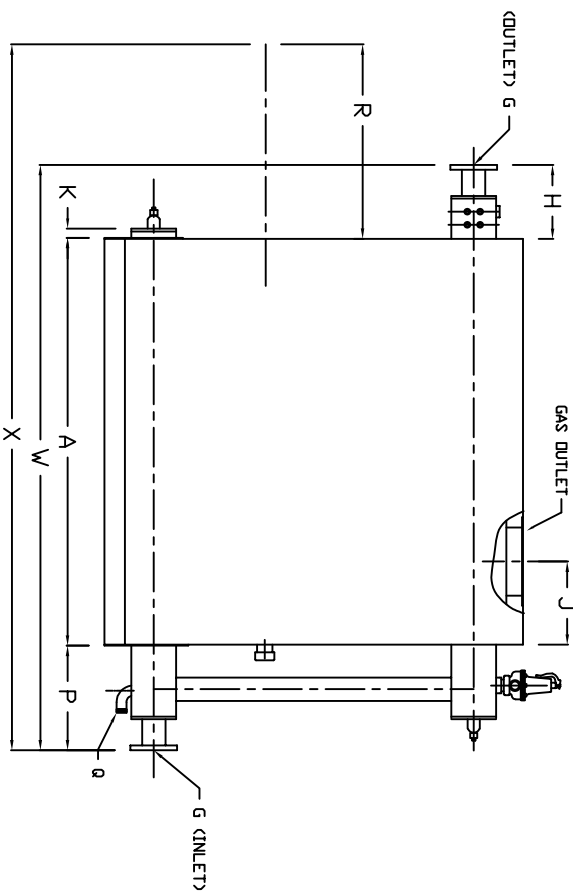

SIDE VIEW

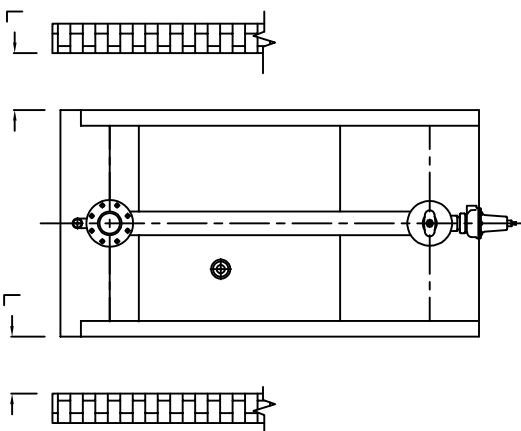

REAR VIEW

| BOILER MODEL - ZF350W-XP | | |
|--------------------------|---------|--------|
| | INCHES | METRIC |
| A | 78 | 1981 |
| B | 80 1/2 | 2044 |
| C | 43 1/2 | 1105 |
| D | 61 1/2 | 1562 |
| E | 9 1/2 | 241 |
| F | 31 | 787 |
| G | 4 | 102 |
| H | 14 1/4 | 362 |
| J | 16 | 406 |
| K | 1 3/4 | 44 |
| L | 26 | 660 |
| M | 8 5/8 | 219 |
| N | 8 5/8 | 219 |
| O | 12 | 305 |
| P | 20 1/8 | 511 |
| Q | 1 1/2 | 38 |
| R | TBD | TBD |
| W | 112 3/8 | 2854 |
| X | TBD | TBD |

NOTE: DIMENSIONS SUBJECT TO CHANGE WITHOUT NOTICE. CONSULT FACTORY FOR CERTIFIED DIMENSIONS.

| | |
|-------------|------------|
| PROJECT: | - |
| LOCATION: | - |
| Model Sizes | ZF 350W-XP |
| BURNER | - |
| ELECTRIC | - |
| SUPPLY PSI | - |

UNILUX ADVANCED MFG., LLC
 30 COMMERCE PARK DRIVE
 NISKAYUNA, NY 12309
 Ph: (518) 344-7490



| | | | |
|---------------|-----------------------|---------|---------|
| Drawn By : | EAN GAVIGAN | Date : | 10OCT24 |
| Checked By : | BRENDAN LEE | Date : | 10OCT24 |
| Drawing No. : | ZF350W-XP - SUBMITTAL | Scale : | 1 |
| File No. : | ZF350W-XP - SUBMITTAL | REV.: | 00 |

| REVISIONS | DATE | BY | Rev No. |
|-----------|------|----|---------|
| | | | |