

ZF600W-XP

CHIMNEY FLANGE DIMS:
 O.D. = 21"
 I.D. = 16-1/4"
 B.C.D = 18-1/2"
 NO. OF HOLES = 8
 HOLE DIAMETER = 0.53"

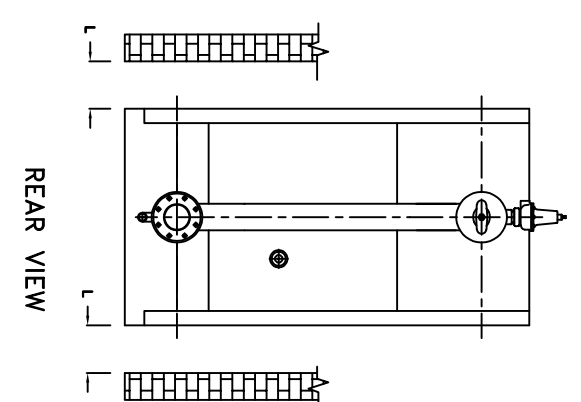
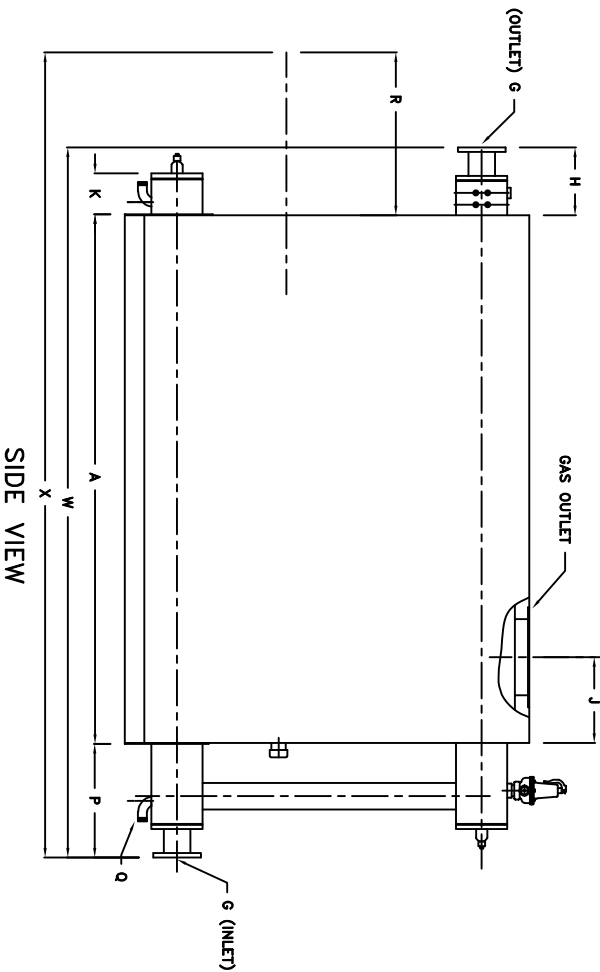
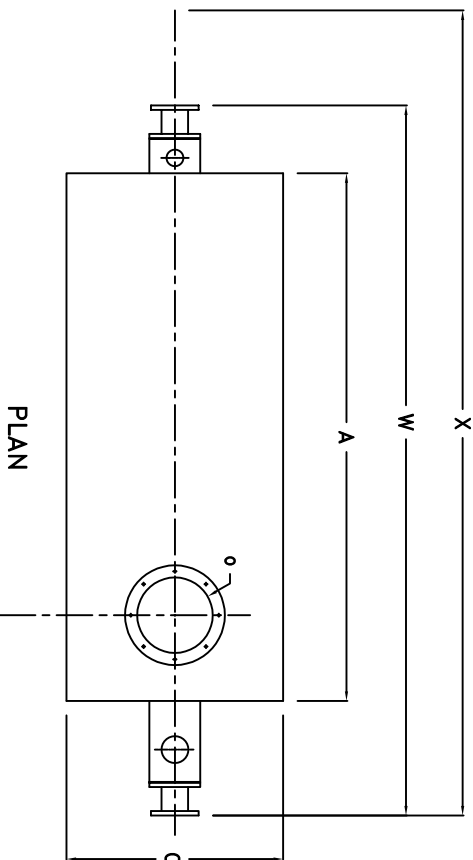
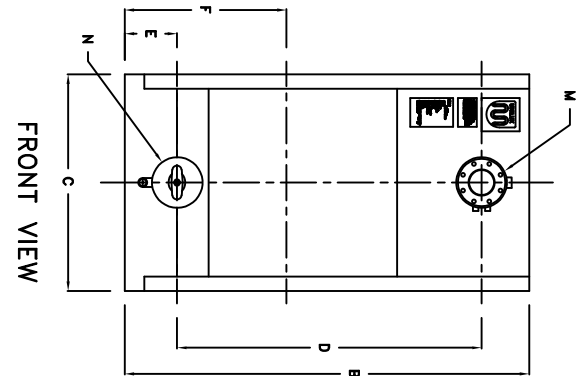

BOILER MODEL - ZF600W-XP	INCHES	METRIC
A LENGTH OF BASE	111 1/4	2826
B HEIGHT	85	2159
C WIDTH OF BASE	45 1/2	1156
D CTR. LOWER DRUM TO CTR. UPPER DRUM	64	1626
E CENTER OF LOWER DRUM TO BOTTOM	11	279
F CENTER OF BURNER OPENING TO BOTTOM	34	864
G INLET / OUTLET FLANGE, CLASS 150	5	127
H NOZZLE CLEARANCE FROM TOP, FRONT	14 1/4	362
J CENTER OF FLUE GAS OUTLET TO REAR	18	457
K TUBE CLEARANCE FROM BASE, FRONT	8 5/8	219
L TUBE REMOVAL CLEARANCE FROM BASE	28	711
M UPPER DRUM, OD, NPS	10 3/4	273
N LOWER DRUM, OD, NPS	16 3/4	423
O FLUE GAS OUTLET, ID	16	406
P NOZZLE CLEARANCE FROM BASE, REAR	23 7/8	606
Q BLOWDOWN, NPT	1 1/2	38
R BURNER DIMENSION	TBD	TBD
W OVERALL BOILER LENGTH	149 3/8	3794
X OVERALL BOILER LENGTH WITH BURNER	TBD	TBD

NOTE: DIMENSIONS SUBJECT TO CHANGE WITHOUT NOTICE.
 CONSULT FACTORY FOR CERTIFIED DIMENSIONS.

PROJECT: -

LOCATION: -

Model Sizes ZF 600W-XP

BURNER -

ELECTRIC -

SUPPLY PSI -

UNILUX ADVANCED MFG., LLC
 30 COMMERCE PARK DRIVE
 NISKAYUNA, NY 12309
 Ph: (518) 344-7490



THIS DRAWING EMBODIES A CONFIDENTIAL PROPRIETARY DESIGN. ALL RIGHTS FOR REPRODUCTION, MANUFACTURING OR PATENT'S ARE RESERVED BY UNILUX BOILER CORP.

Drawn By : EAM GAVIGAN

Checked By : BRENDAN LEE

Drawing No. ZF600W-XP - SUBMITTAL

File No. : ZF600W-XP - SUBMITTAL

Date : 10OCT24

Date : 10OCT24

Scale : 1

REV.: 00

REVISIONS

DATE BY Rev No.