

ZF800W-XP

CHIMNEY FLANGE DIMS:
 O.D. = 23"
 I.D. = 18-1/4"
 B.C.D = 20-1/2"
 NO. OF HOLES = 8
 HOLE DIAMETER = 0.53"

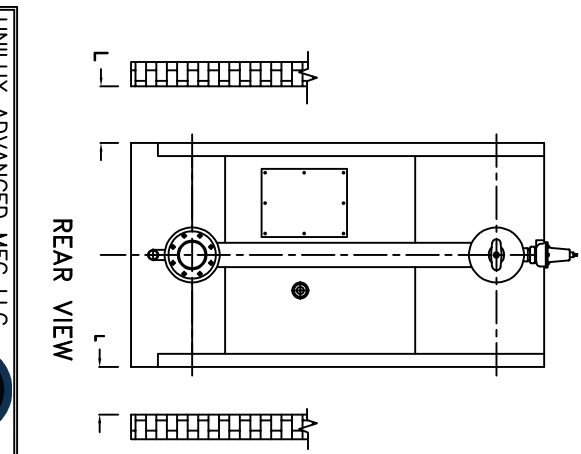
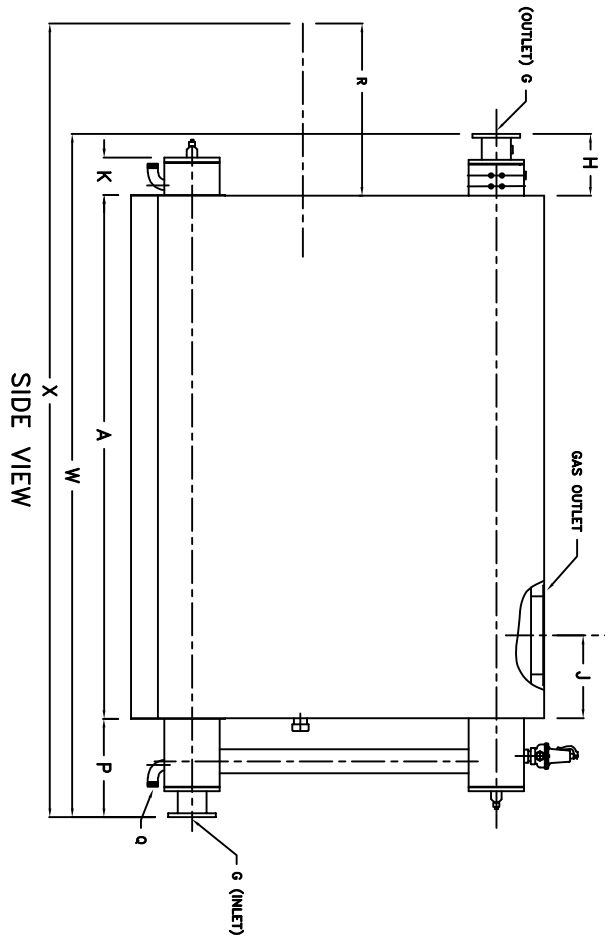
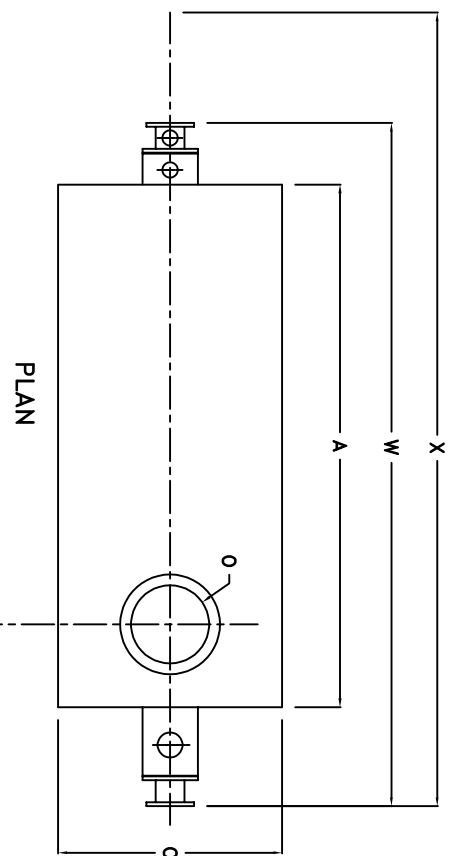
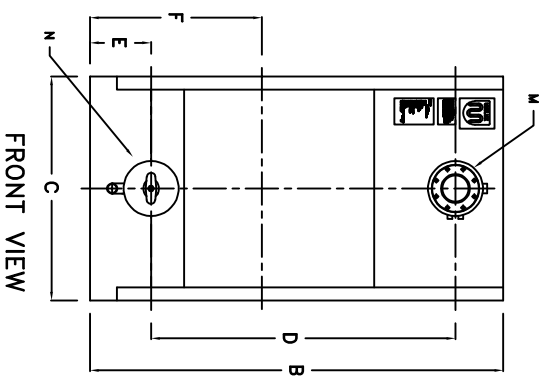

BOILER MODEL - ZF800W-XP	INCHES	METRIC	
A	LENGTH OF BASE	120 1/2	3061
B	HEIGHT	95	2413
C	WIDTH OF BASE	51 1/2	1308
D	CTR. LOWER DRUM TO CTR. UPPER DRUM	70	1778
E	CENTER OF LOWER DRUM TO BOTTOM	14	356
F	CENTER OF BURNER OPENING TO BOTTOM	39 1/2	1003
G	INLET / OUTLET FLANGE CLASS 150	6	152
H	NOZZLE CLEARANCE FROM TOP, FRONT	14 1/4	362
J	CENTER OF FLUE GAS OUTLET TO REAR	19	483
K	DRUM CLEARANCE FROM BASE, FRONT	8 5/8	219
L	TUBE REMOVAL CLEARANCE FROM BASE	34	864
M	UPPER DRUM, OD, NPS	12 3/4	324
N	LOWER DRUM, OD, NPS	12 3/4	324
O	FLUE GAS OUTLET, ID	18	457
P	NOZZLE CLEARANCE FROM BASE, REAR	22 5/8	575
Q	BLOWDOWN, NPT	2	51
R	BURNER DIMENSION	TBA	TBA
W	OVERALL BOILER LENGTH WITH BURNER	157 3/8	3997
X	OVERALL BOILER LENGTH	TBA	TBA

NOTE: DIMENSIONS SUBJECT TO CHANGE WITHOUT NOTICE. CONSULT FACTORY FOR CERTIFIED DIMENSIONS.

REVISIONS	DATE	BY	Rev No.

PROJECT:	-
LOCATION:	-
Model Sizes	ZF 800W-XP
BURNER	-
ELECTRIC	-
SUPPLY PSI	-

UNILUX ADVANCED MFG, LLC
 30 COMMERCE PARK DRIVE
 NISKAYUNA, NY 12309
 Ph: (518) 344-7490

THIS DRAWING ENDOES A CONFIDENTIAL PROPRIETARY DESIGN. ALL RIGHTS FOR REPRODUCTION, MANUFACTURING OR PATENTS ARE RESERVED BY UNILUX BOILER CORP.

Drawn By : EMM GAVIGAN
 Checked By : BRENDAN LEE
 Drawing No. : ZF800W-XP - SUBMITTAL
 File No. : ZF800W-XP - SUBMITTAL

Date : 10OCT24
 Date : 10OCT24
 Scale : 1
 REV. : 00